

Schematic Symbol for XC3S200AFG320

The Schematic symbol consists of 6 heterogeneous parts that are listed below:

1. IO bank 0

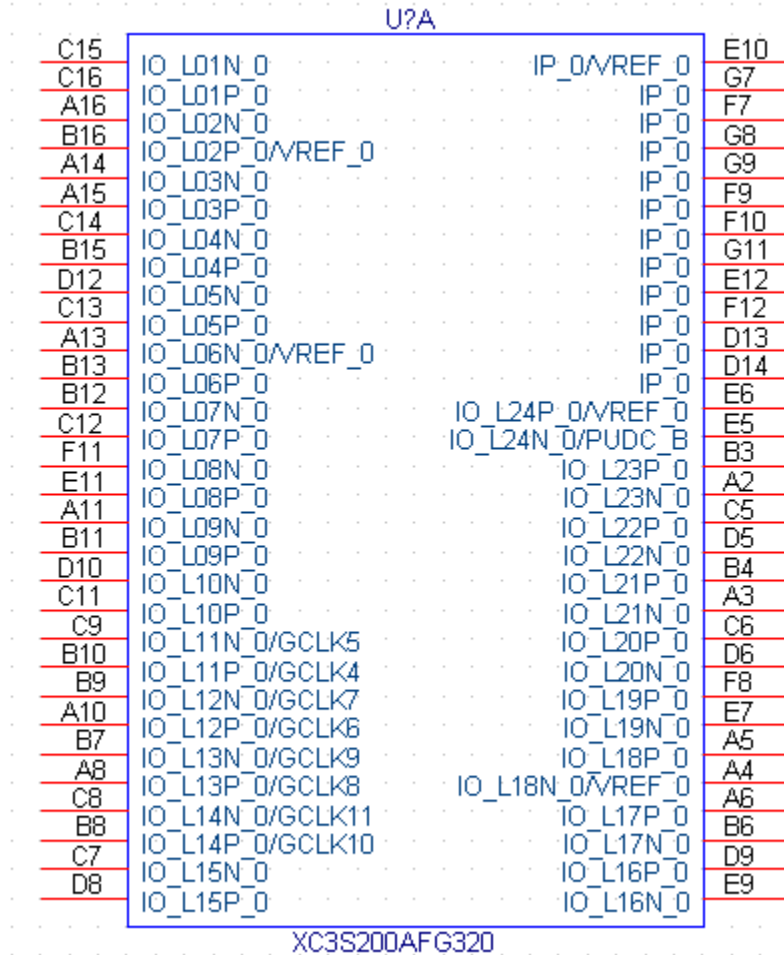

2. IO bank 1

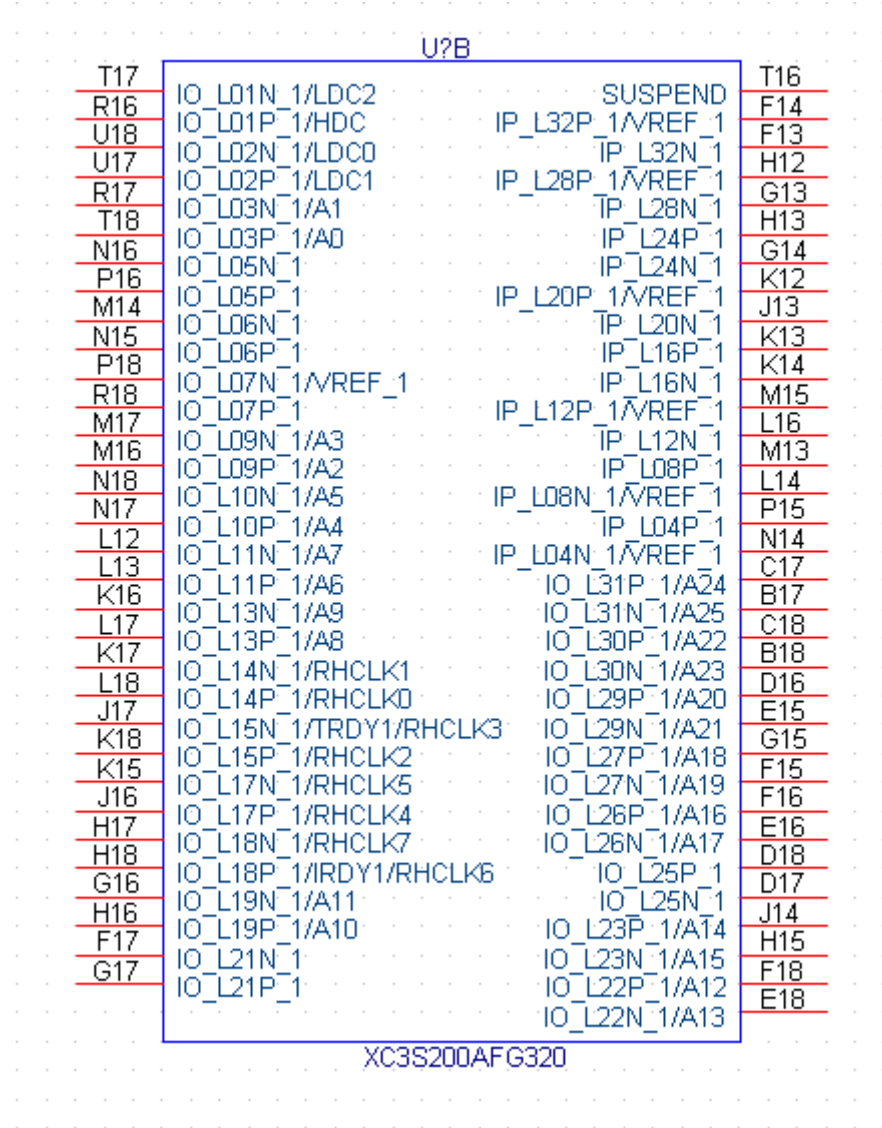

3. IO bank 2

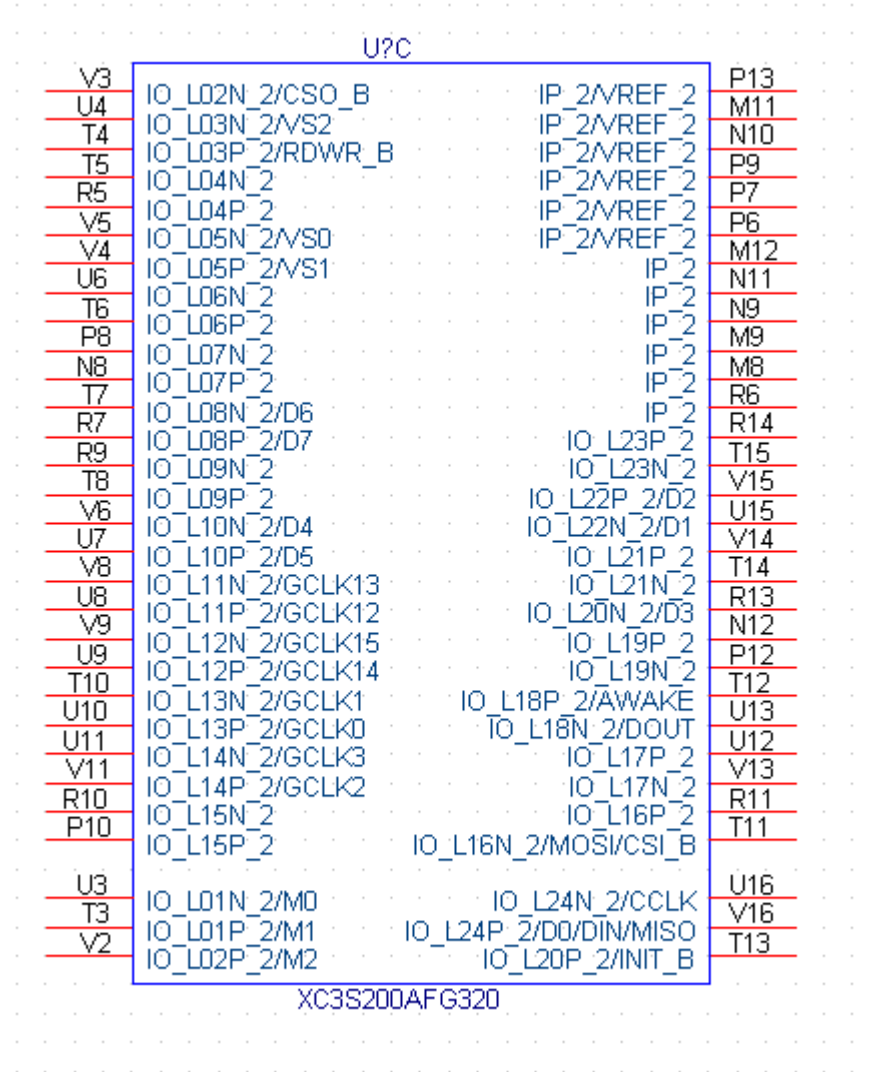

5. Ground

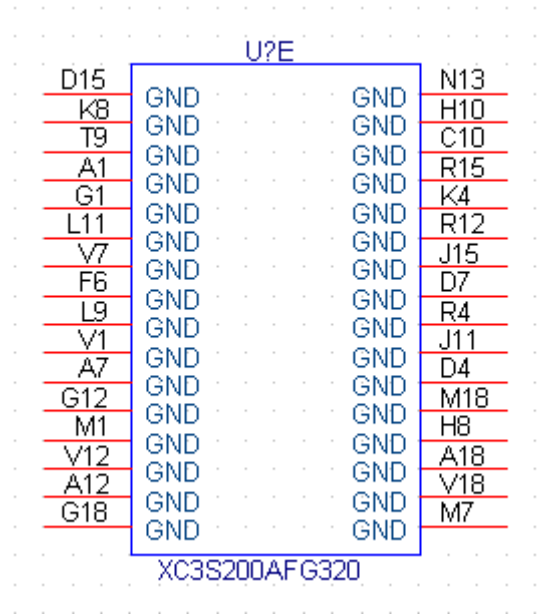

6. Power /Programming

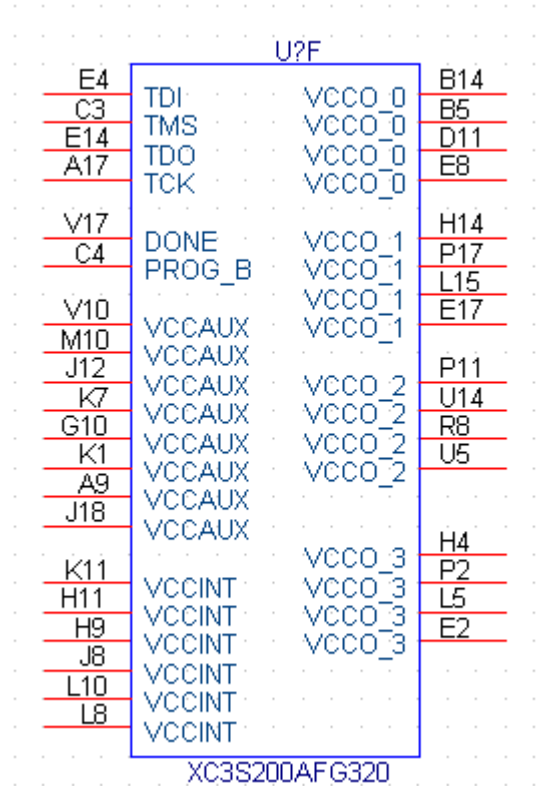

7. Revision History

	Revision	Date	By	Comments
1	1.01	Apr 28, 2007	MD	Initial Release