

Schematic Symbol for 6VLX130T-FF(G)784

The Schematic symbol consists of 18 heterogeneous parts that are listed below:

1. Programming Interface

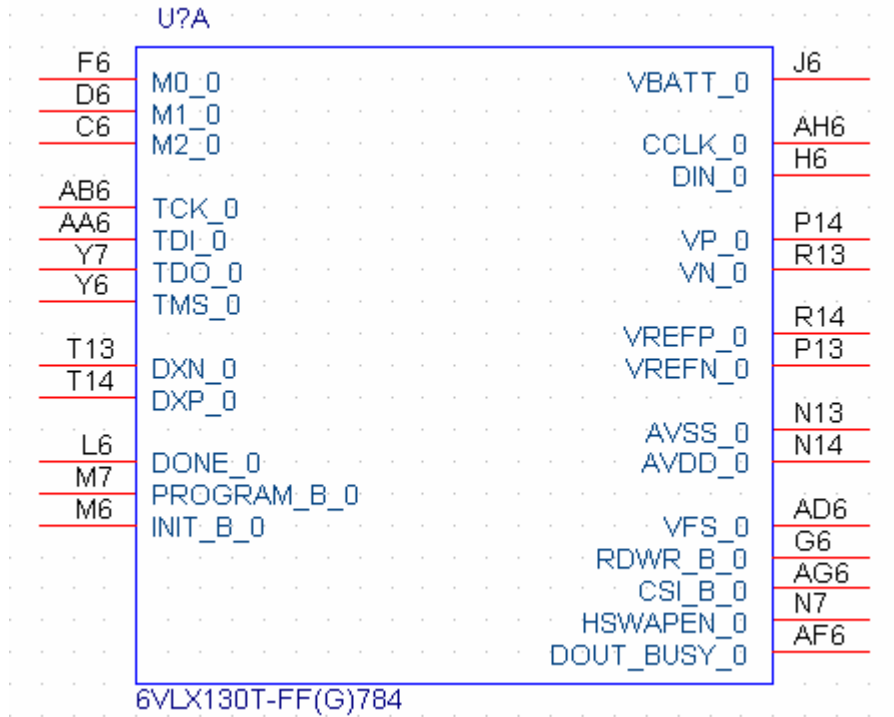

2. I/O Bank 14

U?B			
R28	IO_L0N_14	IO_L9P_MRCC_14	Y23
R27	IO_L0P_14	IO_L9N_MRCC_14	W23
T26	IO_L10N_MRCC_14	IO_L8P_SRCC_14	P21
U26	IO_L10P_MRCC_14	IO_L8N_SRCC_14	P22
U23	IO_L11N_SRCC_14	IO_L7P_14	Y25
V23	IO_L11P_SRCC_14	IO_L7N_14	Y24
R25	IO_L12N_VRP_14	IO_L6P_14	W27
R24	IO_L12P_VRN_14	IO_L6N_14	Y27
W22	IO_L13N_14	IO_L5P_14	Y28
Y22	IO_L13P_14	IO_L5N_14	W28
P20	IO_L14N_VREF_14	IO_L4P_14	W26
R20	IO_L14P_14	IO_L4N_VREF_14	V26
T25	IO_L15N_14	IO_L3P_14	W25
T24	IO_L15P_14	IO_L3N_14	V25
U24	IO_L16N_14	IO_L2P_14	V28
V24	IO_L16P_14	IO_L2N_14	U28
U21	IO_L17N_14	IO_L1P_14	T27
U22	IO_L17P_14	IO_L1N_14	U27
R23	IO_L18N_14	IO_L19P_14	T21
R22	IO_L18P_14	IO_L19N_14	T22

6VLX130T-FF(G)784

3. I/O Bank 15

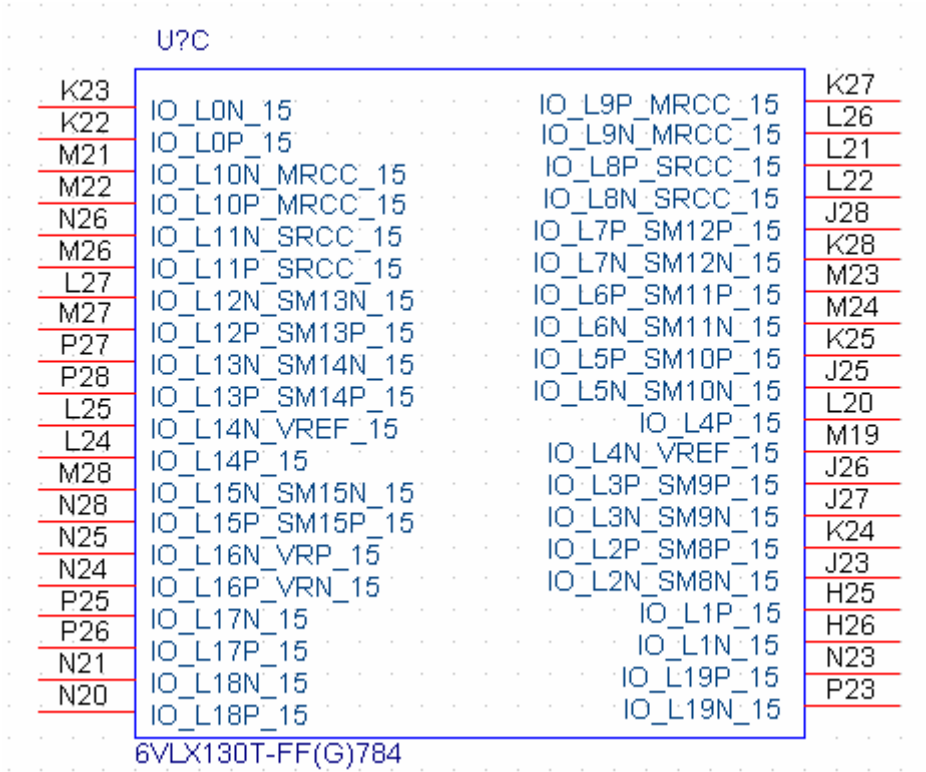

4. I/O Bank 16

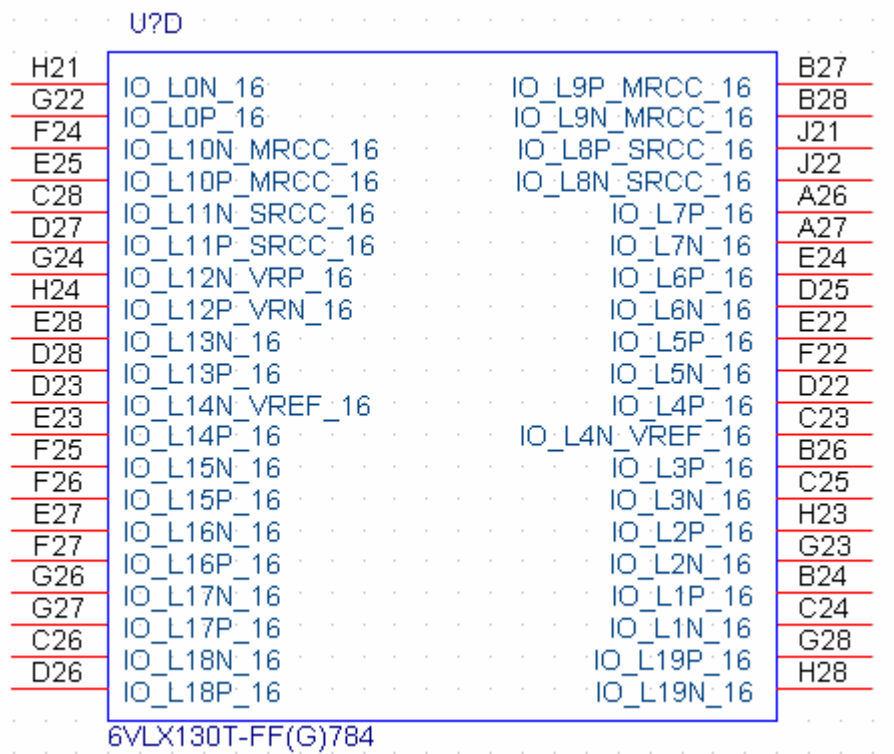

5. I/O Bank 23

U?E			
V21	IO_L0N_23	IO_L9P_MRCC_23	AD21
W21	IO_L0P_23	IO_L9N_MRCC_23	AC20
AE19	IO_L10N_MRCC_23	IO_L8P_SRCC_23	AD20
AF19	IO_L10P_MRCC_23	IO_L8N_SRCC_23	AE20
AA20	IO_L11N_SRCC_23	IO_L7P_23	AG21
Y20	IO_L11P_SRCC_23	IO_L7N_23	AF20
Y19	IO_L12N_VRP_23	IO_L6P_23	Y18
AA19	IO_L12P_VRN_23	IO_L6N_23	W18
AF17	IO_L13N_23	IO_L5P_23	AA21
AG17	IO_L13P_23	IO_L5N_23	AB21
AE18	IO_L14N_VREF_23	IO_L4P_23	AF22
AD18	IO_L14P_23	IO_L4N_VREF_23	AE22
AB19	IO_L15N_23	IO_L3P_23	AG22
AC19	IO_L15P_23	IO_L3N_23	AF21
AC18	IO_L16N_23	IO_L2P_23	V20
AB18	IO_L16P_23	IO_L2N_23	V19
AH21	IO_L17N_23	IO_L1P_23	AD22
AH20	IO_L17P_23	IO_L1N_23	AC21
AH18	IO_L18N_23	IO_L19P_23	AH19
AG18	IO_L18P_23	IO_L19N_23	AG19

6VLX130T-FF(G)784

6. I/O Bank 24

U?F			
AA27			AF26
AA26	IO_L0N_GC_24	IO_L9P_MRCC_24	AG26
AF25	IO_L0P_GC_24	IO_L9N_MRCC_24	AB27
AE25	IO_L10N_MRCC_24	IO_L8P_SRCC_24	AB26
AC23	IO_L10P_MRCC_24	IO_L8N_SRCC_24	AC25
AB23	IO_L11N_SRCC_24	IO_L7P_D5_24	AD25
AD26	IO_L11P_SRCC_24	IO_L7N_D4_24	AA24
AC26	IO_L12N_D2_FS2_24	IO_L6P_D7_24	AA25
AH25	IO_L12P_D3_24	IO_L6N_D6_24	AE28
AH26	IO_L13N_D0_FS0_24	IO_L5P_D9_24	AE27
AF24	IO_L13P_D1_FS1_24	IO_L5N_D8_24	AG27
AE24	IO_L14N_VREF_FOE_B_MOSI_Q24_4P_D11_24	IO_L4P_D11_24	AH28
AH24	IO_L14P_FCS_B_24	IO_L4N_VREF_D10_24	AG28
AG24	IO_L15N_RS1_24	IO_L3P_D13_24	AF27
AB24	IO_L15P_FWE_B_24	IO_L3N_D12_24	AC28
AC24	IO_L16N_CSO_B_24	IO_L2P_D15_24	AB28
AG23	IO_L16P_RS0_24	IO_L2N_D14_24	AD28
AH23	IO_L17N_VRP_24	IO_L1P_GC_24	AD27
AD23	IO_L17P_VRN_24	IO_L1N_GC_24	AB22
AE23	IO_L18N_24	IO_L19P_24	AA22
	IO_L18P_24	IO_L19N_24	

6VLX130T-FF(G)784

7. I/O Bank 25

U?G			
K18	IO_L0N_25	IO_L9P_MRCC_25	H19
K17	IO_L0P_25	IO_L9N_MRCC_25	G19
E19	IO_L10N_MRCC_25	IO_L8P_SRCC_25	A20
D20	IO_L10P_MRCC_25	IO_L8N_SRCC_25	A19
A22	IO_L11N_SRCC_25	IO_L7P_25	E18
A21	IO_L11P_SRCC_25	IO_L7N_25	F19
C20	IO_L12N_25	IO_L6P_25	D17
C19	IO_L12P_25	IO_L6N_25	E17
C21	IO_L13N_25	IO_L5P_25	B18
B21	IO_L13P_25	IO_L5N_25	B19
J20	IO_L14N_VREF_25	IO_L4P_25	G18
K19	IO_L14P_25	IO_L4N_VREF_25	H18
A25	IO_L15N_25	IO_L3P_25	C18
A24	IO_L15P_25	IO_L3N_25	D18
D21	IO_L16N_VRP_25	IO_L2P_25	J17
E20	IO_L16P_VRN_25	IO_L2N_25	J18
B23	IO_L17N_25	IO_L1P_25	G17
B22	IO_L17P_25	IO_L1N_25	F17
G21	IO_L18N_GC_25	IO_L19P_GC_25	F20
H20	IO_L18P_GC_25	IO_L19N_GC_25	F21

6VLX130T-FF(G)784

8. I/O Bank 26

U?H			
D11	IO_L0N_26	IO_L9P_MRCC_26	B14
E12	IO_L0P_26	IO_L9N_MRCC_26	A14
F15	IO_L10N_MRCC_26	IO_L8P_SRCC_26	J15
F16	IO_L10P_MRCC_26	IO_L8N_SRCC_26	K15
F12	IO_L11N_SRCC_26	IO_L7P_26	C14
G12	IO_L11P_SRCC_26	IO_L7N_26	B13
D15	IO_L12N_VRP_26	IO_L6P_26	D13
E15	IO_L12P_VRN_26	IO_L6N_26	D12
A16	IO_L13N_26	IO_L5P_26	B11
A15	IO_L13P_26	IO_L5N_26	C11
A12	IO_L14N_VREF_26	IO_L4P_26	J16
A11	IO_L14P_26	IO_L4N_VREF_26	H15
B16	IO_L15N_26	IO_L3P_26	G14
C15	IO_L15P_26	IO_L3N_26	F14
C16	IO_L16N_26	IO_L2P_26	H16
D16	IO_L16P_26	IO_L2N_26	G16
B17	IO_L17N_26	IO_L1P_26	E13
A17	IO_L17P_26	IO_L1N_26	E14
C13	IO_L18N_26	IO_L19P_26	H14
B12	IO_L18P_26	IO_L19N_26	G13

6VLX130T-FF(G)784

9. I/O Bank 34

U?I			
AD12	IO_L0N_GC_34	IO_L9P_MRCC_34	AH15
AE13	IO_L0P_GC_34	IO_L9N_MRCC_34	AH16
AF15	IO_L10N_MRCC_34	IO_L8P_SRCC_34	Y13
AG14	IO_L10P_MRCC_34	IO_L8N_SRCC_34	AA12
AC15	IO_L11N_SRCC_34	IO_L7P_A05_D21_34	AH13
AD15	IO_L11P_SRCC_34	IO_L7N_A04_D20_34	AH14
AD17	IO_L12N_A02_D18_34	IO_L6P_A07_D23_34	AD13
AE17	IO_L12P_A03_D19_34	IO_L6N_A06_D22_34	AE14
AG16	IO_L13N_A00_D16_34	IO_L5P_A09_D25_34	AB14
AF16	IO_L13P_A01_D17_34	IO_L5N_A08_D24_34	AC14
AC16	IO_L14N_VREF_A24_34	IO_L4P_A11_D27_34	AF14
AB16	IO_L14P_A25_34	IO_L4N_VREF_A10_D26_34	AG13
AE15	IO_L15N_A22_34	IO_L3P_A13_D29_34	AB13
AD16	IO_L15P_A23_34	IO_L3N_A12_D28_34	AA14
Y14	IO_L16N_A20_34	IO_L2P_A15_D31_34	W12
AA15	IO_L16P_A21_34	IO_L2N_A14_D30_34	Y12
AB17	IO_L17N_A18_34	IO_L1P_GC_34	AB12
AA16	IO_L17P_A19_34	IO_L1N_GC_34	AC13
Y15	IO_L18N_A16_34	IO_L19P_VRN_34	Y17
W16	IO_L18P_A17_34	IO_L19N_VRP_34	AA17

6VLX130T-FF(G)784

10. I/O Bank 35

U?J			
Y9	IO_L0N_35	IO_L9P_MRCC_35	AB11
W8	IO_L0P_35	IO_L9N_MRCC_35	AA11
AE7	IO_L10N_MRCC_35	IO_L8P_SRCC_35	W11
AD7	IO_L10P_MRCC_35	IO_L8N_SRCC_35	W10
AG11	IO_L11N_SRCC_35	IO_L7P_SM4P_35	AD11
AF11	IO_L11P_SRCC_35	IO_L7N_SM4N_35	AC11
AE8	IO_L12N_SM5N_35	IO_L6P_SM3P_35	AC8
AF7	IO_L12P_SM5P_35	IO_L6N_SM3N_35	AB8
AH8	IO_L13N_SM6N_35	IO_L5P_SM2P_35	AC10
AG9	IO_L13P_SM6P_35	IO_L5N_SM2N_35	AD10
AF9	IO_L14N_VREF_35	IO_L4P_35	AA9
AE9	IO_L14P_35	IO_L4N_VREF_35	AB9
AE12	IO_L15N_SM7N_35	IO_L3P_SM1P_35	AC9
AF12	IO_L15P_SM7P_35	IO_L3N_SM1N_35	AD8
AG8	IO_L16N_VRP_35	IO_L2P_SM0P_35	AA7
AG7	IO_L16P_VRN_35	IO_L2N_SM0N_35	AB7
AH10	IO_L17N_35	IO_L1P_35	Y10
AH9	IO_L17P_35	IO_L1N_35	AA10
AE10	IO_L18N_GC_35	IO_L19P_GC_35	AH11
AF10	IO_L18P_GC_35	IO_L19N_GC_35	AG12

6VLX130T-FF(G)784

11. I/O Bank 36

U?K			
E10	IO_L0N_36	IO_L9P_MRCC_36	F7
F11	IO_L0P_36	IO_L9N_MRCC_36	G7
H10	IO_L10N_MRCC_36	IO_L8P_SRCC_36	D10
H11	IO_L10P_MRCC_36	IO_L8N_SRCC_36	C10
K13	IO_L11N_SRCC_36	IO_L7P_36	E8
J12	IO_L11P_SRCC_36	IO_L7N_36	F9
C9	IO_L12N_VRP_36	IO_L6P_36	G11
B9	IO_L12P_VRN_36	IO_L6N_36	F10
G9	IO_L13N_36	IO_L5P_36	D8
G8	IO_L13P_36	IO_L5N_36	E9
E7	IO_L14N_VREF_36	IO_L4P_36	H13
D7	IO_L14P_36	IO_L4N_VREF_36	J13
H9	IO_L15N_36	IO_L3P_36	A7
H8	IO_L15P_36	IO_L3N_36	B7
J10	IO_L16N_36	IO_L2P_36	A10
J11	IO_L16P_36	IO_L2N_36	A9
J8	IO_L17N_36	IO_L1P_36	B8
J7	IO_L17P_36	IO_L1N_36	C8
K10	IO_L18N_36	IO_L19P_36	K7
K9	IO_L18P_36	IO_L19N_36	L7

6VLX130T-FF(G)784

12. GND1

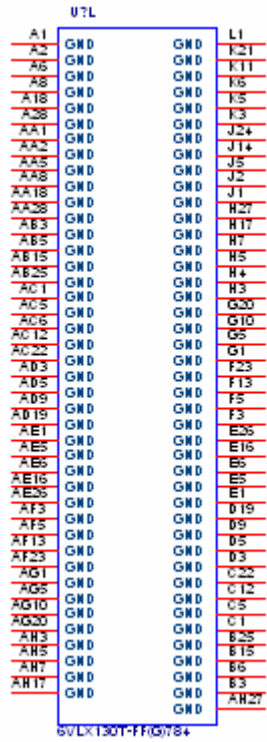

13. GND2

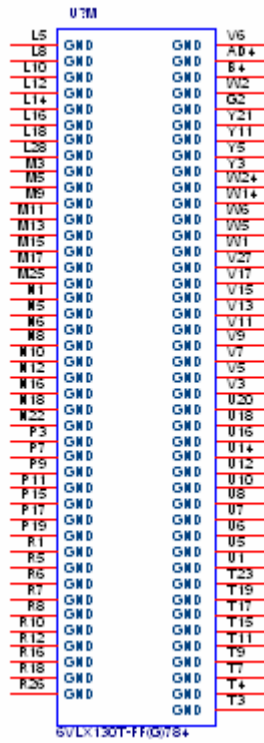

15. Power2

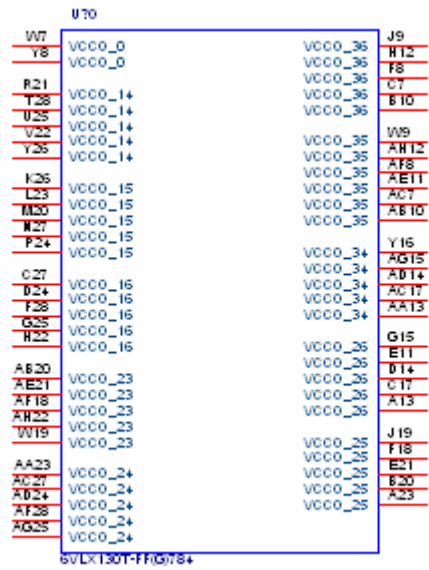

16. MGT 114

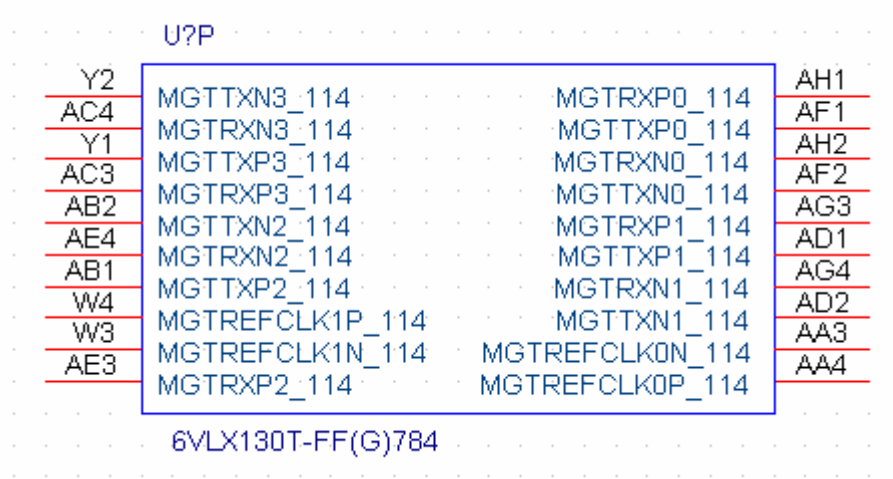

17. MGT 115

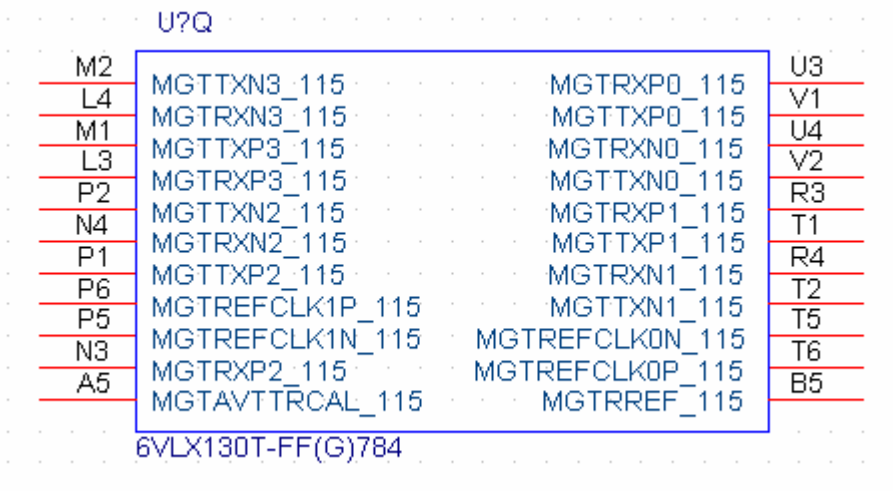

18. MGT 116

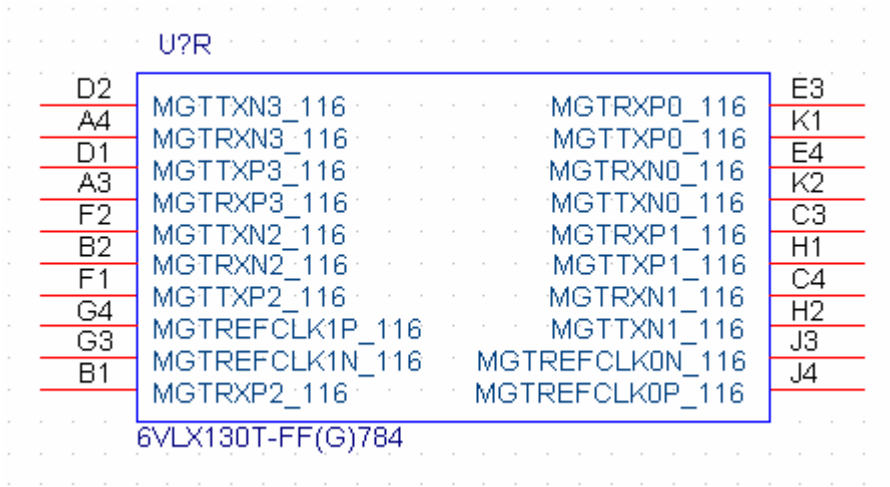

19. Revision History

	Revision	Date	By	Comments
1	1	June 29, 2009	AC	Initial Release